



750 Series Rotary Sprinkler

INSTALLATION & SERVICE INSTRUCTIONS

Introduction

The 754 Full-Circle Rotary Sprinkler is designed for irrigation of large turf areas such as golf courses, parks, recreational fields and school grounds.

Manufactured from durable, high-strength engineering plastic and stainless-steel components, the 754 sprinkler incorporates many innovative and time-proven features for lasting, maintenance-free operation. Some of these features are listed below:

Specifications

- Radius: 56 ft. – 100 ft. (17.1 m – 30.4 m)
- Flow Rate:
 - 13.0 – 60.1 GPM
 - 49.2 – 227.5 l/mn
 - 3.0 – 13.7 m³/hr
- Arc: Full Circle
- Maximum Pressure:
 - Electric VIH - 150 PSI (10.5 kg/cm²) (1034.5 kPa)
 - NO Hyd. VIH - 100 PSI (7.0 kg/cm²) (689.7 kPa)
 - NC Hyd. VIH - 150 PSI (10.5 kg/cm²) (1034.5 kPa)
 - Check-O-Matic - 100 PSI (7.0 kg/cm²) (689.7 kPa)
- Body Height: 11 in. (27.9 cm)
- Pop-Up Height: 2.75 in. (6.9 cm)
- Pop-Up to Nozzle: 2 in. (5.1 cm)
- 1.5 in. NPT, BSP or ACME Female Thread Inlet
- Solenoid:
 - 24 VAC, 50/60 Hz
 - Inrush Current: 50 Hz, 0.47 Amps (11.3 VA)
60 Hz, 0.40 Amps (9.6 VA)
 - Holding Current: 50 Hz, 0.32 Amps (7.7 VA)
60 Hz, 0.30 Amps (7.2 VA)
- Manual Control: On-Off-Auto
- Check-O-Matic model checks up to 37 ft. (11.3 m) of elevation
- Color-Coded Nozzles: See chart on page 2.

Features

- Full 3" pop-up to clear taller grasses
- Nozzles color-coded by radius and gallonage
- Caps serve as yardage markers or effluent water indicators
- Variable stator
- Four standard pressure-regulation settings available to ensure consistently accurate nozzle performance regardless of elevation:
 - 50 PSI, 65 PSI, 80 PSI and 100 PSI (electric)
- Four body styles/activation types to fit every application: Electric VIH, Normally Open Hydraulic VIH, and Check-O-Matic
- Manual control at the sprinkler, On-Off-Auto (electric)
- Bowl-vented discharge (atmospheric) minimizes the differential pressure required for regulation and ensures positive valve closure (electric)
- Time-proven planetary gear-drive design
- All internal components serviceable from the top of the sprinkler
- Large selection of color-coded nozzles available
- Durable engineering plastic and stainless-steel construction
- Effluent indicators available
 - Marker (Part No. 89-4719)
 - Yardage marker (Part No. 89-4736)



750 Electric



750 Normally Open Valve-In-Head



750 Check-O-Matic

750 Series Sprinkler Nozzle Performance Data

NOZZLE PERFORMANCE — U.S.

BASE PRESSURE	NOZZLE SET 52 ORANGE		NOZZLE SET 53 BROWN		NOZZLE SET 54 BLUE		NOZZLE SET 55 GREEN		NOZZLE SET 56 RED		NOZZLE SET 57 GRAY		NOZZLE SET 58 BEIGE		NOZZLE SET 59 BLACK	
	Rad	GPM	Rad	GPM	Rad	GPM	Rad	GPM	Rad	GPM	Rad	GPM	Rad	GPM	Rad	GPM
50	56	13.0	61	16.8	65	20.0	67	25.3	68	30.0	70	32.5	73	37.4	78	40.1
55	57	13.5	62	17.6	66	20.9	68	26.5	69	31.5	73	33.6	76	38.9	81	41.6
60	57	14.0	62	18.3	68	21.8	69	27.7	71	33.0	77	34.7	78	40.4	84	43.1
65	58	14.5	63	19.1	69	22.8	70	28.9	72	34.6	80	35.8	81	41.9	87	44.5
70	59	15.0	65	19.8	72	23.6	73	29.9	75	36.0	81	37.3	83	43.7	89	46.4
75	59	15.6	66	20.4	72	24.5	73	30.9	75	37.4	83	38.8	84	45.5	90	48.3
80	60	16.1	68	21.1	74	25.3	75	32.0	77	38.9	84	40.3	86	47.4	92	50.2
85	62	17.4	69	22.2	75	26.8	76	33.4	78	39.9	86	41.7	88	50.2	94	52.7
90	63	18.7	70	23.4	76	28.4	78	34.8	80	41.0	87	43.1	89	53.0	96	55.2
95	65	19.9	71	24.5	76	29.9	79	36.2	81	42.0	89	44.4	91	55.7	98	57.6
100	66	21.2	72	25.6	77	31.4	80	37.6	82	43.0	90	46.8	92	58.6	100	60.1

Rad = feet GPM = gallons per minute = Pressure regulation = Nozzles not recommended at this pressure

NOZZLE PERFORMANCE — METRIC

BASE PRESSURE	NOZZLE SET 52 ORANGE			NOZZLE SET 53 BROWN			NOZZLE SET 54 BLUE			NOZZLE SET 55 GREEN			NOZZLE SET 56 RED			NOZZLE SET 57 GRAY			NOZZLE SET 58 BEIGE			NOZZLE SET 59 BLACK			
	kg/cm²	kPa	Rad	l/mn	m³/hr	Rad	l/mn	m³/hr	Rad	l/mn	m³/hr	Rad	l/mn	m³/hr	Rad	l/mn	m³/hr	Rad	l/mn	m³/hr	Rad	l/mn	m³/hr	Rad	l/mn
3.5	344.7	17.1	49.2	3.0	18.6	63.6	3.8	19.8	75.7	4.5	20.4	95.8	5.7	20.7	113.6	6.8	21.4	123.0	7.4	22.3	141.6	8.5	23.8	151.8	9.1
3.9	379.2	17.4	51.1	3.1	18.9	66.6	4.0	20.1	79.1	4.7	20.7	100.3	6.0	21.0	119.2	7.2	22.3	127.2	7.6	23.2	147.2	8.8	24.7	157.5	9.4
4.2	413.7	17.4	53.0	3.2	18.9	69.3	4.2	20.7	82.5	5.0	21.0	104.8	6.3	21.7	124.9	7.5	23.5	131.3	7.9	23.8	152.9	9.2	25.6	163.1	9.8
4.6	448.2	17.7	54.9	3.3	19.2	72.3	4.3	21.0	86.3	5.2	21.4	109.4	6.6	22.0	131.0	7.9	24.4	135.5	8.1	24.7	158.6	9.5	26.5	168.4	10.1
4.9	482.6	18.0	56.8	3.4	19.8	74.9	4.5	22.0	89.3	5.4	22.3	113.2	6.8	22.9	136.3	8.2	24.7	141.2	8.5	25.3	165.4	9.9	27.1	175.6	10.5
5.3	517.1	18.0	59.0	3.5	20.1	77.2	4.6	22.0	92.7	5.6	22.3	117.0	7.0	22.9	141.6	8.5	25.3	146.9	8.8	25.6	172.2	10.3	27.5	182.8	11.0
5.6	551.6	18.3	60.9	3.7	20.7	79.9	4.8	22.6	95.8	5.7	22.9	121.1	7.3	23.5	147.2	8.8	25.6	152.5	9.2	26.2	179.4	10.8	28.1	190.0	11.4
6.0	586.1	18.9	65.9	4.0	21.0	84.0	5.0	22.9	101.4	6.1	23.2	126.4	7.6	23.8	151.0	9.1	26.2	157.8	9.5	26.8	190.0	11.4	28.7	199.5	12.0
6.3	620.5	19.2	70.8	4.2	21.4	88.6	5.3	23.2	107.5	6.5	23.8	131.7	7.9	24.4	155.2	9.3	26.5	163.1	9.8	27.1	200.6	12.0	29.3	208.9	12.5
6.7	655.0	19.8	75.3	4.5	21.7	92.7	5.6	23.2	113.2	6.8	24.1	137.0	8.2	24.7	159.0	9.5	27.1	168.1	10.1	27.8	210.8	12.7	29.9	218.0	13.1
7.0	689.5	20.1	80.2	4.8	22.0	96.9	5.8	23.5	118.8	7.1	24.4	142.3	8.5	25.0	162.8	9.8	27.5	177.1	10.6	28.1	221.8	13.3	30.5	227.5	13.7

kPa = kilo Pascals Rad = meters l/mn = liters per minute m³/hr - cubic meters per hour = Pressure regulation = Nozzles not recommended at this pressure

Sprinkler Spacing

- The Toro Company does not recommend designing for zero (0) mph wind conditions. Design in consideration of the worst wind conditions.
- Square Spacing
 - No wind - 55% of diameter
 - 4 mph wind - 50% of diameter
 - 8 mph wind - 45% of diameter
- Triangular Spacing
 - No wind - 60% of diameter
 - 4 mph wind - 55% of diameter
 - 8 mph wind - 50% of diameter
- Single-Row Spacing
 - No wind - 50% of diameter
 - 4 mph wind - 50% of diameter
 - 8 mph wind - 45% of diameter

Nozzle Color-Coding Guide			
Nozzle Set	Short Main	Long Main	Long Inner
52	Orange		Red
53	Brown		Red
54	Blue		Red
55		Green	Black
56		Red	Black
57		Gray	Black
58		Beige	Green
59		Black	Green

Precipitation Rate Formulas

- Square-spaced sprinklers in pattern:

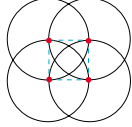
$$\frac{\text{GPM of full circle} \times 96.3}{(\text{Spacing})^2}$$

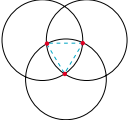
- Triangular-spaced sprinklers in pattern:

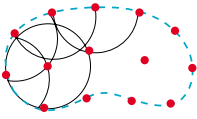
$$\frac{\text{GPM of full circle} \times 96.3}{(\text{Spacing})^2 (0.866)}$$

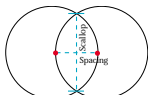
- Area and flow:

$$\frac{\text{Total GPM of zone} \times 96.3}{\text{Total irrigated square feet of zone}}$$

- Single row:

$$\frac{\text{GPM of full circle} \times 96.3}{(\text{Spacing}) (\text{Scallop})}$$

For additional information, refer to Toro Form No. 490-1737.

Installation Procedure

CAUTION

Golf sprinklers are intended for installation at grade with full support of the body and piping system from the surrounding earth. Failure to provide full support may result in premature failure of the body and/or connecting fittings.

To assure maximum performance from your 754 Series Rotary Sprinklers, read these instructions completely prior to installation or service.

Swing Joints

1. Construct or provide triple swing joints for each sprinkler as shown in **Figure 1**. Use PVC or ABS pipe nipple for sprinkler connection.

Note: On sites where the possibility of heavy equipment rolling over a sprinkler exists, the swing joint will flex preventing damage to the lateral or main lines. On a new installation in raw ground where the sprinklers are to be initially installed above the finished grade and lowered when new turf is established, the swing joint allows sprinkler repositioning without changing risers. This is a common and practical procedure which eliminates the problem of dirt being accidentally introduced into the lateral lines when a riser is changed.

2. Flush lines thoroughly prior to installing sprinkler.

3. NPT and BSP Threaded Models

- Apply teflon tape on riser threads. Install sprinkler onto riser and tighten.

ACME Threaded Models

- Install ACME threaded bodies onto Acme threaded swing joint by threading clockwise until hand tight

Note: ACME threaded swing joints have an o-ring that seals to the sprinkler body. Teflon tape is not required..

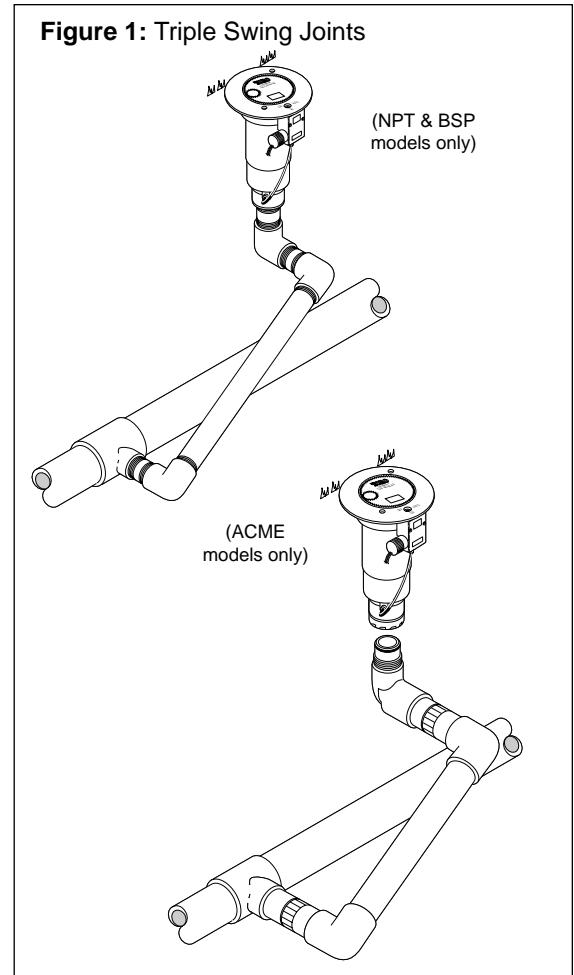

CAUTION

Use only Teflon™ tape on riser threads. Use of pipe dope or other types of sealing compounds can cause deterioration of sprinkler body threads.

Connecting Electric Control Wires

1. Route control wires to sprinkler location(s). Provide enough extra wire at sprinkler to allow for movement of sprinkler without straining wire connections. One common wire and station wire is required for each sprinkler. See Wire Sizing Chart, **Table 1** for proper application.
2. Attach control wires to solenoid leads using an approved waterproof splicing method.

CAUTION

All wires must be waterproofed to prevent short circuit to ground and subsequent controller damage.

Table 1: Wire Sizing Chart

Maximum allowable length in feet from controller to electric VIH sprinklers.

OUTPUT VOLTAGE AT CONTROLLER TRANSFORMER	WIRE SIZE		NUMBER OF VALVES			
	CONTROL	COMMON	1	2	3	4
23 VAC	14	14	2348	1012	549	353
23 VAC	14	12	2890	1239	673	433
23 VAC	14	10	3378	1448	786	505
23 VAC	12	12	3759	1604	873	561
23 VAC	12	10	4591	1973	1071	688
23 VAC	12	8	5411	2328	1263	812
23 VAC	10	10	5945	2555	1387	892
24 VAC	14	14	2765	1309	846	549
24 VAC	14	12	3393	1608	1039	673
24 VAC	14	10	3962	1877	1213	783
24 VAC	12	12	4394	2082	1346	872
24 VAC	12	10	5397	2557	1652	1071
24 VAC	12	8	6364	3018	1949	1263
24 VAC	10	10	6986	3311	2140	1387

NOTE: Minimum solenoid voltage required for reliable electric VIH operation is 20 VAC.

Chart based on the following

- Transformer - 115/230 VAC - 24 VAC, 45 VA
- Coil Assy. - 24 VAC, 60 Hz
- Holding - .30 Amps
- In Rush - .40 Amps

Connecting Hydraulic Control Tubing

1. Route control tubing from controller to sprinkler location(s).

Note: Leave an 18 inch (45.7 cm) service loop of tubing at each sprinkler to facilitate movement of sprinkler and service operations. Refer to **Table 2** for tubing run length information.

2. Flush tubing thoroughly to remove all air and debris.
3. Remove tube retainer and poly cap from tubing adapter at base of sprinkler.
4. Slide tube retainer over control tubing and attach tubing to adapter. Slide tube retainer over adapter area to secure tubing.

Type of System*	Maximum Distance From Controller	Elevation Restrictions
Pin-type [£] (00) Hydraulic* with 1/8" Control Tubing	100'	
Pin-type [£] (00) Hydraulic* with 1/4" Control Tubing	200'	
Normally Open (01) with 1/8" Control Tubing	500'	Valve elevation should not exceed 25' ABOVE controller elevation or 70' BELOW controller elevation.
Normally Closed (08) with 1/8" Control Tubing	500'	Valve elevation should not exceed 0' ABOVE controller elevation or 70' BELOW controller elevation.
Normally Open (01) with 1/4" Control Tubing	1000'	Valve elevation should not exceed 25' ABOVE controller elevation or 70' BELOW controller elevation.
Normally Closed (08) with 1/4" Control Tubing	1000'	Valve elevation should not exceed 0' ABOVE controller elevation or 70' BELOW controller elevation.

- * - All hydraulic connections on Toro valves are 1/4" insert type.
- Control line pressure must be equal to or 10% greater than mainline pressure.
- Control line pressure range is 40 to 150 PSI
- £ NOTE: Maximum of one (1) valve pr station on pin-type systems.

System Start-Up

The following is a recommended procedure that will protect system components during system start-up. The procedure is based on a velocity fill rate of less than 2' (.61 m) per second. See **Table 3** below.

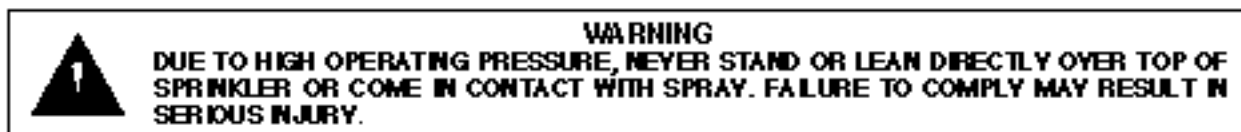

1. Use jockey pump only to fill system at velocity fill rate of less than 2' (0.6 m) per second.
2. Use quick coupler keys at all tees and greens with quick coupler valves to bleed air from system lines during filling process. Do not compress air and then relieve, bleed air while filling system.
3. After water has filled all lines and all air is removed, remove quick coupler keys.

CAUTION

Failure to comply with recommended fill rate will increase line pressure resulting in a water hammer effect that could damage sprinklers.

Table 3: Recommended System Fill Rate

Pipe Size		Flow		Velocity		Pipe Size		Flow		Velocity	
in.	cm	GPM	LPM	ft/sec	m/sec	in.	cm	GPM	LPM	ft/sec	m/sec
1/2	1.3	2	7.6	1.60	0.49	3	7.6	45	170.3	1.86	0.57
3/4	1.9	3	11.4	1.92	0.59	4	10.2	75	283.9	1.87	0.57
1	2.5	5	18.9	1.50	0.46	6	15.2	150	567.8	1.73	0.53
1-1/4	3.2	10	37.9	1.86	0.57	8	20.2	250	946.3	1.70	0.52
1-1/2	3.8	10	37.9	1.41	0.43	10	25.4	450	1703.3	1.97	0.60
2	5.0	20	75.7	1.80	0.55	12	30.5	500	1892.5	1.55	0.47
2-1/2	6.4	30	113.6	1.84	0.56						

Pilot Valve Operation (Models 7XX-X6-XXX Only)

The main function of the pilot valve is to control the operation of the main valve located in the base of the sprinkler body. The main valve is operated by the release of water metered through the pilot valve when it is activated either manually at the sprinkler or by the irrigation system controller.

Another important function of the pilot valve is to regulate the water pressure to the sprinkler nozzle. Pressure regulation compensates for large variations within the system and maintains a constant pressure for optimum sprinkler operation. The pilot valve is factory set to regulate one of four pressure levels 50 psi (3.5 kg/cm²), 65 psi (4.6 kg/cm²), 80 psi (6.0 kg/cm²) or 100 PSI (7.0 kg/cm²).

The sprinkler operation mode is set using a Toro Selector Tool (P/N 995-15) inserted through the body flange onto the pilot valve D-shaped selector cam. The "AUTO" mode permits automatic operation from the system controller. The "ON" mode opens the main valve for manual operation and "OFF" mode prevents the main valve from opening.



System Troubleshooting — Pilot Valve

Possible equipment failures with causes and corrective action are listed below.

PROBLEM	POSSIBLE CAUSE – CORRECTIVE ACTION
1. SPRINKLER WILL NOT TURN ON	<p>(a) No 24 VAC to coil assembly. (Electric Models) – Measure voltage with a Digital Volt Meter (DVM). Check wiring and controller program. – Refer to Controller Operating Instructions.</p> <p>(b) Selector cam in "OFF" position. – Set to "AUTO" position.</p> <p>(c) Debris in pilot valve assembly. – Disassemble and remove all debris. (See Servicing Pilot Valve page 10.)</p>
2. SPRINKLER WILL NOT SHUT OFF	<p>(a) Constant 24 VAC from controller. (Electric Models) – Check for voltage using a DVM. If voltage is present, disconnect wire. If sprinkler closes, service controller. Refer to Controller Service Manual.</p> <p>(b) Selector cam in manual "ON" position. – Set to "AUTO" or "OFF" position.</p> <p>(c) Debris in pilot valve assembly. – Disassemble and remove all debris. (See Servicing Pilot Valve page 10.)</p>

System Troubleshooting — Sprinklers

PROBLEM	POSSIBLE CAUSE – CORRECTIVE ACTION
1. SPRINKLER WON'T ROTATE	<ul style="list-style-type: none"> (a) Debris wedged between stator and turbine. – <i>Remove obstruction.</i> (b) Drive assembly defective. – <i>Replace drive assembly.</i> (c) Nozzle base assembly defective. – <i>Replace nozzle base assembly.</i>
2. HEAD STICKS UP	<ul style="list-style-type: none"> (a) Dirt in riser assembly. – <i>Flush out. (See Flushing Procedure on page 10.)</i> (b) Damaged or missing return spring. – <i>Replace.</i> (c) Damaged riser. – <i>Replace.</i>
3. POOR DISTRIBUTION PATTERN	<ul style="list-style-type: none"> (a) Nozzle plugged with debris. – <i>Clean or replace nozzle.</i> (b) Nozzle orifice damaged. – <i>Replace nozzle.</i> (c) Low operating pressure. – <i>Determine why system overloaded and correct.</i>
4. VALVE WON'T CLOSE (Electric 7XX-X6-XXX)	<ul style="list-style-type: none"> (a) Continuous 24 VAC to sprinkler. – <i>Check controller for voltage source.</i> (b) Leak in pilot valve assembly. – <i>Replace pilot valve assembly.</i> (c) Plugged supply screen on piston. – <i>Clean or replace screen.</i> (d) Manual control selector on pilot valve assembly turned to "ON" position. – <i>Turn to "AUTO" position.</i> (e) Solenoid plunger movement restricted. – <i>Inspect and clean or replace.</i> (f) Valve cylinder misaligned with sprinkler body communication tube. – <i>Remove valve assembly and install correctly.</i> (g) Foreign object keeping valve from seating. – <i>Remove, clean and check valve for damage. Replace if necessary.</i> (h) Damaged piston seal or piston assembly. – <i>Replace valve assembly.</i>
VALVE WON'T CLOSE (Hyd. Normally Open 7XX-X1-XX)	<ul style="list-style-type: none"> (a) Leak in control tubing. – <i>Isolate and repair.</i> (b) Pilot valve leak in controller. – <i>Confirm by observing constant dripping from discharge line of controller. Refer to Controller Service Manual.</i> (c) Valve cylinder misaligned with sprinkler body communication tube. – <i>Remove valve assembly and install correctly.</i> (d) Foreign object keeping valve from seating. – <i>Remove, clean and check valve for damage. Replace if necessary.</i> (e) Damaged piston seal or piston assembly. – <i>Replace valve assembly.</i>

System Troubleshooting — Sprinklers (continued)

PROBLEM	POSSIBLE CAUSE – CORRECTIVE ACTION
5. VALVE WON'T OPEN (Electric 7XX-X6-XXX)	<ul style="list-style-type: none">(a) Control (field) wires severed. – <i>Isolate and repair.</i>(b) No power to controller. – <i>Establish controller power.</i>(c) No power from controller to solenoid. – <i>Check for blown fuse and replace.</i>(d) Manual control selector on pilot valve assembly turned to "OFF" position. – <i>Turn to "AUTO" position.</i>(e) Pilot valve solenoid inoperative. – <i>Remove and replace.</i>(f) Solenoid plunger movement restricted. – <i>Inspect, clean and/or replace.</i>(g) No supply from main valve. – <i>Debris in control tube, main valve assembly and/or communication passages in body. Flush thoroughly.</i>
VALVE WON'T OPEN (Hyd. Normally Open 7XX-X1-XX)	<ul style="list-style-type: none">(a) Plugged controller discharge line or discharge port in pilot valve. – <i>Verify by checking for discharge at discharge line when station is activated. If no discharge, refer to Controller Service Manual.</i>
6. SPRINKLER WEEPING (Slow leak in valve)	<ul style="list-style-type: none">(a) Damaged or blocked valve seat. – <i>Remove blockage and, if necessary, replace valve assembly.</i>(b) Damaged piston seal or piston assembly. – <i>Replace valve assembly.</i>(c) Low pressure on supply line on hydraulic NO sprinklers. – <i>Check for low pressure reason and correct.</i>
7. SEVERAL VALVES ON DIFFERENT STATIONS FAIL TO CLOSE (Hyd. Normally Open 7XX-X1-XX)	<ul style="list-style-type: none">(a) Control tubing leak which lowers supply pressure to other stations. – <i>Turn controller from station to station until a station is reached where only valves on that station stay open. The leak would be in the tubing on that station. Isolate and repair.</i>(b) Leak in supply line to controller. – <i>Verify by checking pressure in all control lines.</i>(c) Leak in controller pilot valve. – <i>Verify by constant discharge on controller. Refer to Controller Service Manual.</i>(d) Plugged supply line filter. – <i>Replace filter if more than 3 PSI (0.21 kg/cm²) differential exists.</i>

Servicing Procedures

Introduction

The 754 sprinkler is designed to provide the user trouble-free operation for many years without scheduled maintenance. Should it become necessary to disassemble the sprinkler to correct a malfunction or replace a component, all internal parts of the sprinkler are accessible from the top. Refer to the Troubleshooting Procedure in this manual in the event of a malfunction. Some special tools are required for disassembly and/or maintenance of the sprinkler and are available from your Toro dealer.

	WARNING TO PREVENT POSSIBLE INJURY DURING SPRINKLER SERVICING PROCEDURES, CONFIRM THE FOLLOWING CONDITIONS EXIST PRIOR TO STARTING. A. WATER SUPPLY TO SPRINKLER IS SHUT OFF AT SOURCE. B. SYSTEM PRESSURE IS BLED FROM SYSTEM, INCLUDING CONTROL TUBES. C. A.C. POWER IS DISCONNECTED AT SOURCE.
---	--

Servicing Sprinkler Mechanism

Refer to Toro Illustrated Parts Breakout Book, Form No. 368-0044 for parts identification.

1. Lift Cap using knife blade edge or small screwdriver tip inserted between edge of Cap and Body flange.
2. Grasping edges of Cap, pull sprinkler mechanism up until fully extended.
3. While firmly holding Riser Assembly, remove Cap/Nozzle assembly by turning it counterclockwise. Allow Riser Assembly to slowly retract into body.
4. Using two small screwdrivers inserted between Nozzle and Cap, separate Cap from Nozzle Assembly (retained by press fit).
5. To change Nozzles, carefully insert knife blade edge between nozzle flange and base. Pry nozzle loose and remove. Align new nozzle as shown in illustration at right. Carefully press new nozzles into Nozzle Base until flange is fully seated. *Avoid contact with nozzle orifice as sprinkler coverage can be greatly impaired if orifice is damaged or altered in any way.*
6. Using Multi-Purpose Tool (P/N 995-83) remove Snap Ring from groove in body.
7. Thread Drive Assembly Extraction Tool (995-78) onto drive assembly output shaft and pull sprinkler assembly out of body.
8. Carefully remove O-ring from top of riser housing.
9. Using Multi-Purpose Tool (P/N 995-83) remove screen by turning it counterclockwise while holding base of riser assembly.
10. Remove Variable Stator.
11. Remove Drive Assembly by pushing against end of threaded output shaft.
12. Inspect Stator Housing for nicks and burrs. *This part can be difficult to remove if sprinkler has been in operation for some time and should be left in place if it appears undamaged.* If replacement is necessary, grasp housing with pliers and pull from riser housing.
13. Thoroughly clean and inspect all parts. Replace damaged parts as necessary and reassemble in reverse order.

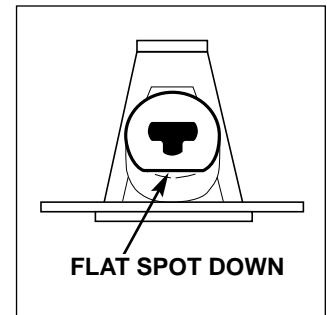

Valve Removal and Replacement

Refer to Toro Illustrated Parts Breakout Book, Form No. 368-0044 for parts identification.

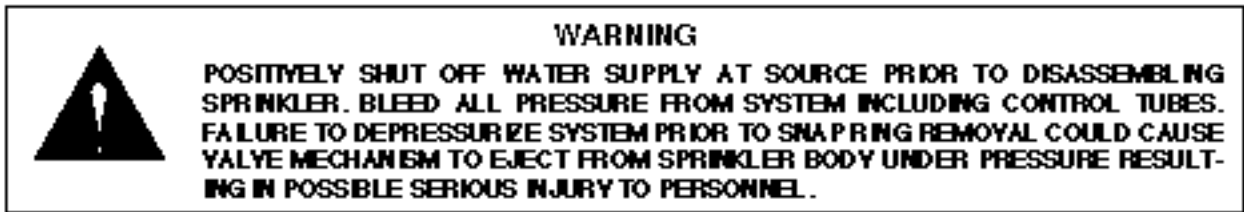

1. To remove valve assembly, squeeze ears of snap ring together with snap ring pliers (P/N 995-07) and remove snap ring from sprinkler body. (See **Figure 2**.)

CAUTION

If snap ring is difficult to remove, there may be residual water pressure in the system. Recheck the water supply to ensure it is turned off and all pressure has been totally eliminated before removing the snap ring and valve.

2. Use valve removal tool (P/N 995-09) to remove valve assembly from base of sprinkler body. Valve Removal Tool is inserted into sprinkler body and pushed through valve ribs to the underside of valve. A slight twist will lock tool to valve enabling removal by pulling straight up and out. (See **Figure 3**.)

NOTE: If valve removal tool is not available, use snap ring pliers to grasp rib of valve cylinder assembly and pull up and out of sprinkler body.

3. To reinstall valve assembly with snap ring and to prevent damage to the communication tube in sprinkler body, use valve insertion tool (P/N 995-10). Valve insertion tool will automatically line up valve assembly with sprinkler body communication tube and correctly seat the snap ring. (See **Figure 4**.)

NOTE: It is possible to install the snap ring backwards (upside down). See inset in **Figure 4** to insure that snap ring is placed on the insertion tool in the correct manner.

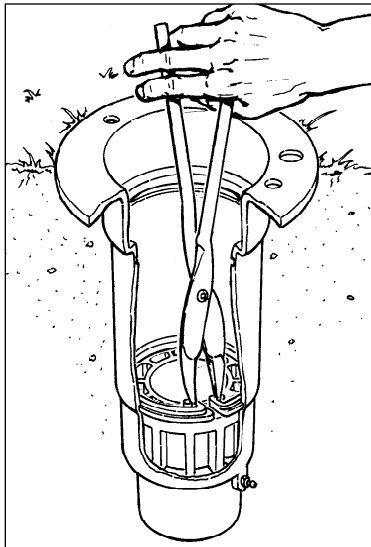

Figure 2
Using Snap Ring Pliers to Remove Snap Ring

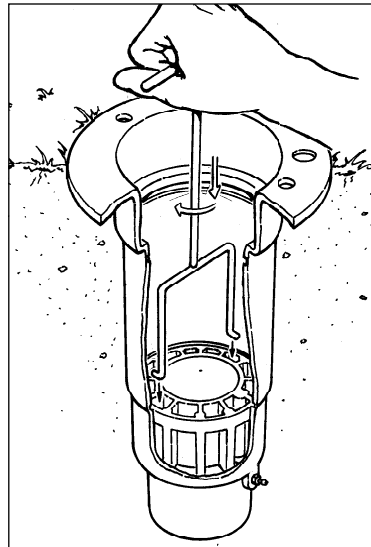

Figure 3
Using Valve Removal Tool to Remove Valve Assembly

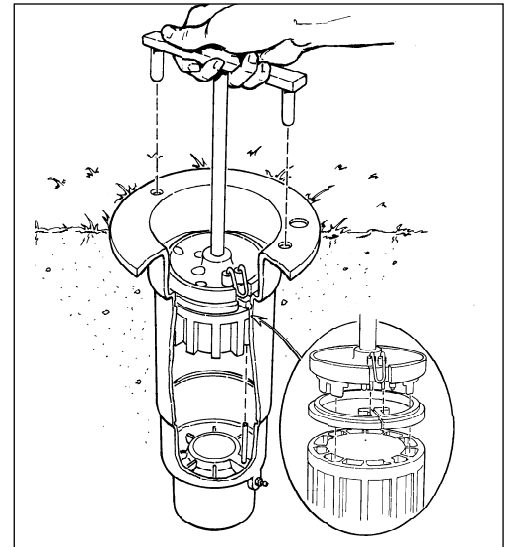
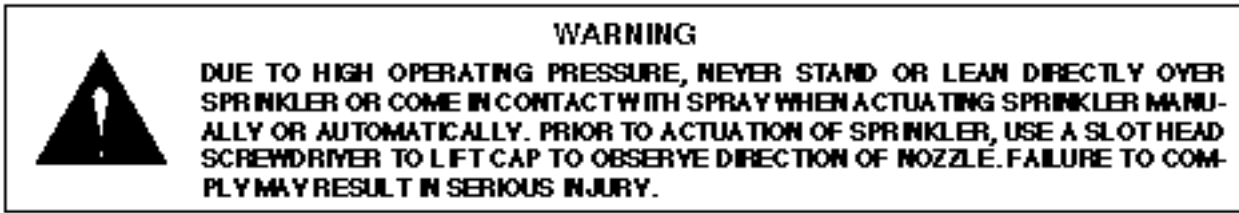

Figure 4
Using Valve Insertion Tool to Install Valve Assembly with Snap Ring

Flushing Sprinkler Heads



1. With sprinkler operating, carefully step down on center of cap several times. Water will flow around riser and flush out debris.
2. Cycle sprinkler on and off several times to check for proper retraction. Cap should be even with top of body flange when fully retracted. If riser sticks in up position, check for debris lodged between riser and body. Flush out all debris. Remove sprinkler mechanism if necessary.

Servicing Pilot Valve

Refer to Toro Illustrated Parts Breakout Book, Form No. 368-0044 for parts identification.

1. Assure water supply to sprinkler is positively shut off and any residual pressure has been bled. *If sprinkler is pressurized, main valve will open when Pilot Valve is disconnected from control tube.*
2. Carefully remove turf and soil from side of sprinkler to expose Pilot Valve and control tubing.
3. Remove two retaining screws from Housing.
4. Pull Pilot Valve assembly away from sprinkler body and cut control tubing just below Tube Retainer. *Unless Pilot Valve has been previously removed, control tubing length will be sufficient for re-connection.*
5. Remove Tube Retainer and remaining piece of control tubing from valve body fitting.
6. Remove Solenoid Assembly or NC Pilot Valve Adapter by turning it counterclockwise.
7. Pull Pilot Valve Body Assembly out of Housing.
8. Remove Diaphragm Assembly, Piston and Spring.
9. Remove Selector and Plunger Assembly. *Selector retains Plunger in body.*
10. Thoroughly clean and inspect all parts. Replace damaged parts as necessary and reassemble in reverse order.



© 1997 THE TORO COMPANY
Irrigation Division • An ISO 9001-Certified Facility
P.O. Box 489
Riverside, California 92502
Printed in U.S.A.

PRINTING DATE
AUGUST 1997 • REV. C

FORM NO.
368-0054