

- ① APPROVED BACKFILL
- ② TORO DT3X-X2-XXX SPRINKLER
- ③ MANUFACTURED SWING JOINT
- ④ LATERAL PIPE
- ⑤ LATERAL TEE

NOTE: INSTALL SPRINKLER AT FINISHED GRADE

SECTION/ELEVATION

(FULL/PART-CIRCLE, CHECK-O-MATIC)
**LARGE TURF GEARED ROTOR
 TORO DT3X SERIES**

NOT TO SCALE

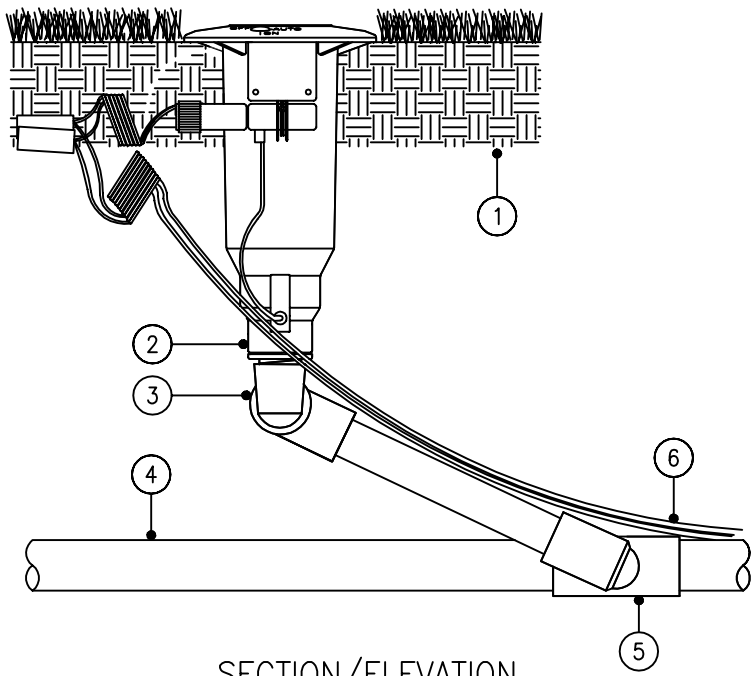

- ① APPROVED BACKFILL
- ② TORO DT3X-X6-XXXX SPRINKLER
- ③ MANUFACTURED SWING JOINT
- ④ PRESSURIZED MAIN OR LATERAL PIPE
- ⑤ LATERAL TEE
- ⑥ CONTROL WIRES WITH 12" MIN. SERVICE COIL AND WATERPROOF WIRE SPLICE CONNECTORS

NOTE: INSTALL SPRINKLER AT FINISHED GRADE

SECTION/ELEVATION

(FULL/PART-CIRCLE, ELECTRIC VALVE-IN-HEAD)
**LARGE TURF GEARED ROTOR
 TORO DT3X SERIES**

NOT TO SCALE

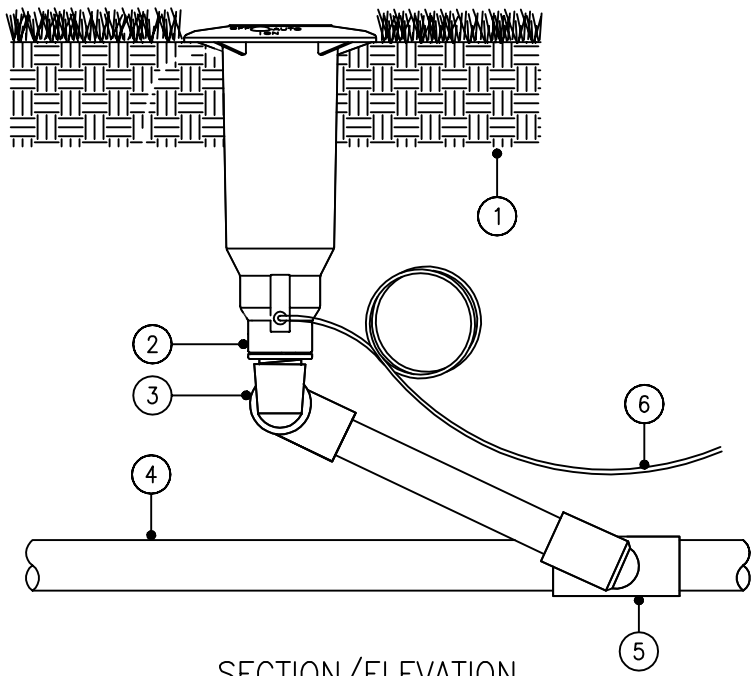

- ① APPROVED BACKFILL
- ② TORO DT3X-X1-XXX SPRINKLER
- ③ MANUFACTURED SWING JOINT
- ④ PRESSURIZED MAIN OR LATERAL PIPE
- ⑤ LATERAL TEE
- ⑥ HYDRAULIC CONTROL LINE WITH SERVICE/EXPANSION COIL

NOTE: INSTALL SPRINKLER AT FINISHED GRADE

SECTION/ELEVATION
 (FULL/PART-CIRCLE, N.O. HYDRAULIC VALVE-IN-HEAD)
**LARGE TURF GEARED ROTOR
 TORO DT3X SERIES**

NOT TO SCALE